

# Data sheet

## DCCS2 OM3 6xLC-D link

Page 1/9

P/N  
130D2F572XXXXE

2018-13-03

### Illustrations



### Dimensional drawing

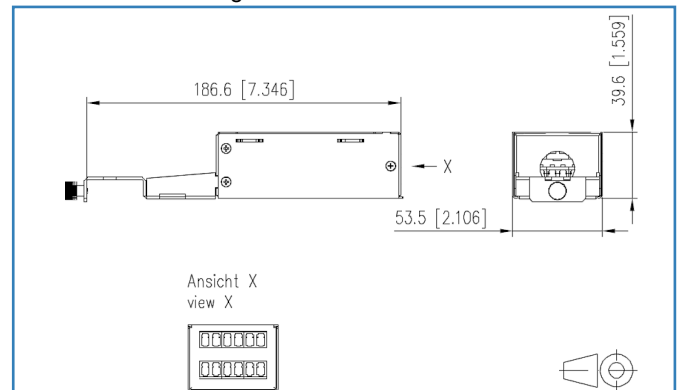

See enlarged drawings at the end of document

### Product specification

- prefabricated fiber optic link consisting of 2 subassemblies DCCS2 each with 6 LC-D adapters mounted to a 12 fiber mini breakout cable
- port numbering of the DCCS2 19 inches subassembly frame remains in place when installing the FO subassemblies
- for 10 GBit Ethernet (IEEE 802.3an)
- the locking levers of patch cords connected to DCCS2 subassemblies show upwards and are easy to handle at any time
- solid and refined assembly housing
- cable diameter less than 6.5 mm
- delivery with serial number and 12 attenuation measurement reports
- mounting version: DCCS2
- available in prefabricated, customer specific lengths - replace xxx in the part number by the length - examples: 0050 = 5.0 m; 0100 = 10.0 m; 0995 = 99.5 m; 2000 = 200.0 m
- maximum length: 500 m
- variants: blue (OS2), lime green (OM5), violet (OM4), aqua (OM3) or green (OS2 APC)



## Technical Data

### General Data

Fields of application	Data center
Design	Subassembly
Mounting style	DCCS
Shielding	shielded
Transmission technology	Fiber optic
Wiring	crossed
Port numbering	yes
Color	aqua
Dimensions	
Dimension (L x W x H)	186.60 x 53.50 x 39.6 mm
Dimension (L x W x H)	7.346 x 2.106 x 1.559 in.
Mode type of the fiber	Multimode
Fiber class	OM3 (ISO/IEC 11801/EN 50173 & IEC 60793-2-10/EN 60793-2-10 A1.a.2)
Cable Type	Mini breakout
Number of cables/ cores	1
Fiber construction	50/125 µm
Maximum length	500.00 m

### Transmission characteristics

Transmission rate up to 10 GBit (Gigabit-Ethernet)	IEEE 802.3an
Reach	
Reach 100BASE	2000 m
Reach 1000BASE LX	550 m
Reach 1000BASE SX	1000 m
Reach 10GBASE LX4	300 m
Reach 10GBASE SW/SR	300 m
Reach 40GBASE SR4	100 m
Overfilled (OFL) modal bandwidth at 850 nm (min.)	1500 MHz * km
Overfilled (OFL) modal bandwidth at 1300 nm (min.)	500 MHz * km
Effective modal bandwidth (EMB) at 850 nm (min.)	2000 MHz * km

### Technical Data

#### Connections/interfaces

Connector technology interface 1	LC-D
Connector technology interface 2	LC-D
Number of ports interface 1	6
Number of ports interface 2	6
Number of equipped ports interface 1	6
Number of equipped ports interface 2	6
Number of ports with dust protection interface 2	6
Cable sheath diameter (min. - max.)	
Cable sheath diameter	6.5 mm
Cable sheath diameter	0.256 in.

#### Mechanical characteristics

Connector type	Duplex
strain relief	cable tie + fixing bolt for the kevlar of the cable
Maximum installation load	50.00 mm
Maximum installation load	1.969 in.
Maximum operating bending radius	100.00 mm
Maximum operating bending radius	3.937 in.

#### Materials and material properties

Material - Coupler housing	Plastics
Material - Housing	sheet steel
Material - Housing finish	Zn (zinc)
Material - Sleeve	ceramic, slotted

#### Approvals

RoHS	compliant
------	-----------

#### The product meets the following standards

Tests on electric and optical fibre cables under fire conditions	
Test for vertical flame propagation for a single insulated wire or cable	DIN EN 60332-1-2
Test for vertical flame propagation for a single insulated wire or cable	ISO/IEC 60332-1-2
Test for vertical flame spread of vertically-mounted bunched wires or cables	ISO/IEC 60332-3-24

### Technical Data

#### The product meets the following standards

Measurement of smoke density of cables burning	ISO/IEC 61034-2
TIA/ANSI-492	AAAC

#### Packing details

Type of packaging	pc(s)
-------------------	-------



### Accessories

P/N	Designation
130D2B1B-E	DCCS2 BGT 19 inch 1RU subrack black
130D2B1G-E	DCCS2 BGT 19 inch 1RU subrack light gray



**Illustrations**

Dimensional drawing

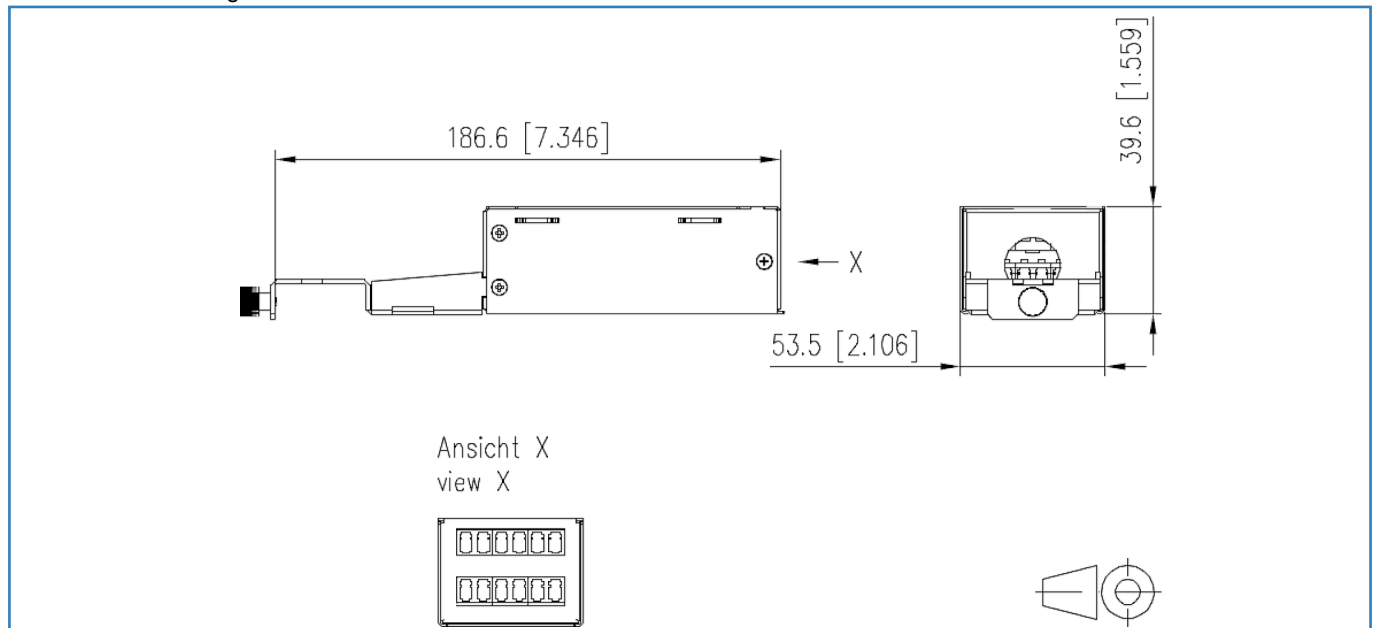

## Data sheet OpDAT fiber OM3 BR

Page 7/9

P/N  
150XXX5

2018-13-03

### Technical Data

#### General Data

Transmission technology	Fiber optic
Mode type of the fiber	Multimode
Fiber class	OM3 (ISO/IEC 11801/EN 50173 & IEC 60793-2-10/EN 60793-2-10 A1.a.2)
Fiber construction	50/125 µm

#### Transmission characteristics

Transmission rate up to 10 GBit (Gigabit-Ethernet)	IEEE 802.3an
Transmission rate up to 100 GBit	IEEE 802.3ba
Reach	
Reach 1000BASE SX	1000 m
Reichweite 10GBASE SR	300 m
Reach 40GBASE SR4	140 m
Reichweite 100GBASE SR4	70 m
Reichweite 100GBASE SR10	140 m
Overfilled (OFL) modal bandwidth at 850 nm (min.)	1500 MHz * km
Overfilled (OFL) modal bandwidth at 1300 nm (min.)	500 MHz * km
Effective modal bandwidth (EMB) at 850 nm (min.)	2000 MHz * km

#### Connections/interfaces

Connector technology interface 1	Free line end
Connector technology interface 2	Free line end
Fiber core diameter	50 ± 2.5 µm
Core-/ Fiber cladding diameter	125.0 ± 1.0 µm
Primary coating diameter - colored	250 ± 15 µm
Primary coating diameter - uncolored	242 ± 7 µm

#### Optical characteristics

Attenuation of the fiber	
Attenuation of the fiber in the cable at 850 nm	max. 2.5 dB/km
Attenuation of the fiber in the cable at 1300 nm	max. 0.7 dB/km
Maximum value of cable attenuation at 850 nm	3.0 dB/km
Maximum value of cable attenuation at 1300 nm	1.0 dB/km



### Technical Data

#### Mechanical characteristics

Proof stress level	min. 0.7 (~ 1 %) GPa
Typische durchschnittliche Abziehkraft	min. 1.0 max. 3.0 N
Strip force (peak)	min. 1.3 max. 8.9 N
Biegeverlust	
Dornradius = 7.5 mm, 2 Umdrehungen bei 850/1300 nm	min. 0.2 - max 0.5 dB
Dornradius = 15 mm, 2 Umdrehungen bei 850/1300 nm	min. 0.1 - max 0.3 dB
Fiber cladding non-circularity	max. 0.7 %
Core non-circularity	max. 5 %
Core (MDF)-cladding concentricity error	max. 1 µm
Primary coating concentricity error	max. 5 %
Primary coating-cladding concentricity error	max. 6
Inhomogeneity of OTDR measurement report at 1310 nm und 1550 nm	max. 0.1 dB/km
Group refractive index	
Gruppen-Brechungsindex bei 850 nm	1.482
Gruppen-Brechungsindex bei 1300 nm	1.477
Numerical aperture	0.200 ± 0.015

#### Materials and material properties

Bend insensitivity	yes
--------------------	-----

#### The product meets the following standards

Generic cabling systems	
General requirements	ISO/IEC 11801 cat. OM3   TIA/EIA 568-C
Data centers	ISO/IEC 24764
Optical fibers: Measuring methods and test procedures	
Fibre geometry	ISO/IEC 60793-1-20
Coating geometry	ISO/IEC 60793-1-21
Length measurement	ISO/IEC 60793-1-22
Fibre proof test	ISO/IEC 60793-1-30
Coating strippability	ISO/IEC 60793-1-32
Attenuation	ISO/IEC 60793-1-40
Bandbreite	ISO/IEC 60793-1-41
Numerical aperture	ISO/IEC 60793-1-43
Gruppenlaufzeitdifferenz	ISO/IEC 60793-1-49



## Technical Data

### The product meets the following standards

Optical fibers: Product specifications

Sectional specification for category A1 multimode fibres	ISO/IEC 60793-2-10 (A1a.2)
ITU-T standard	G.651.1
TIA/ANSI-492	AAAC

