

Data sheet

OpDAT pigtail E2000-APC, OS2, yellow

Page 1/8

P/N
150Q1MA0020S
EAN 4250184164692

2018-09-01

Illustrations

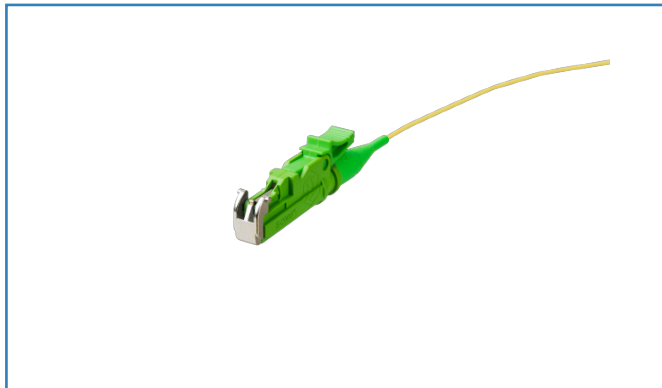

Dimensional drawing

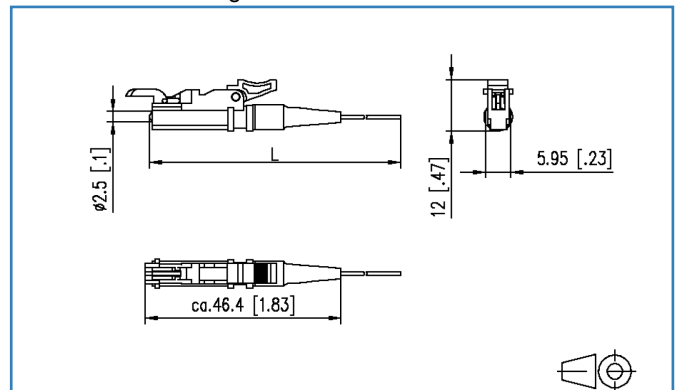

See enlarged drawings at the end of document

Product specification

- E2000 plug according to IEC 61754-15
- Single mode fiber OS2, E9/125 μm , bend insensitive according to IEC 60793-2-50 type B6_a and B6_b and G.657.A2 and B2, compatible to G.652.D
- Compact loose tube fiber with dia. 0.9 mm, length 2.0 m
- Color sequence in sets according to IEC 60304: red, green, blue, yellow, white, gray, brown, violet, turquoise, black, orange, pink. Secondary and primary coating same color
- Plug connector mounted on one side
- With test report, insertion loss and return loss tested at 100 %
- all available variants can be created with the cable configurator



Technical Data

General Data

Fields of application	Office Data center
Design	pigtail
Transmission technology	Fiber optic
Color	green
Dimensions	
Dimension (L x W x H)	46.40 x 5.95 x 12.00 mm
Dimension (L x W x H)	1.827 x 0.234 x 0.472 in.
Mode type of the fiber	Single mode
Fiber class	OS2 (IEC 60793-2-50 B6_a, B6_b & ITU-T G.657.A2, G.657.B2, G.652.D)
Cable Type	pigtail(s)
Number of cables/ cores	1
Number of fibres each cable/ wire	1
Shape	APC (Angled Physical Contact)
Fiber construction	9/125 µm
Cable length (m)	2.00 m
Cable length (ft)	6.56 ft

Connections/interfaces

Connector technology interface 1	Free line end
Connector technology interface 2	E2000 APC
Secondary coating diameter	0.90 mm
Secondary coating diameter	0.035 in.
Ferrule diameter	2.50 mm
Ferrule diameter	0.098 in.

Optical characteristics

Insertion loss	max. 0.3 dB
Return loss	min. 65 dB

Technical Data

Materials and material properties

Bend insensitivity	yes
--------------------	-----

Environmental conditions

Temperature (min. - max.)	
Temperature - Storage °C	-20 - 60 °C
Temperature - Storage °F	-4 - 140 °F
Temperature - Operating °C	-20 - 60 °C
Temperature - Operating °F	-4 - 140 °F

Approvals

RoHS	compliant
------	-----------

The product meets the following standards

Generic cabling systems	
General requirements	ISO/IEC 11801
Fibre optic connector interfaces	IEC 61754-15
Optical fibers: Indoor optical cables	
Sectional specification for class B single-mode fibres	ISO/IEC 60793-2-50 type B6_a/B6_b
Optical fibers - Interconnecting devices and passive components - basic test and measuring methods	
Fibre optic interconnecting devices and passive components	IEC 61300-3-4 ISO/IEC 61300-3-6
ITU-T standard	ITU-T G.657.A2 and G.657.B2, compatible with ITU-T G.652.D

Classifications

ETIM 5.0	EC000748
ETIM 6.0	EC000748

Packing details

Type of packaging	1 pc(s) / plastic bag
Packaging dimension (W x H x D)	160.00 x 100.00 x 380.00 mm
Packaging dimension (W x H x D)	6.299 x 3.937 x 14.961 in.



Data sheet

OpDAT pigtail E2000-APC, OS2, yellow

Page 4/8

P/N

150Q1MA0020S

EAN 4250184164692

2018-09-01

Accessories

P/N	Designation
15090401-I	OpDAT crimp splice protection (150 pcs)
15090402-I	OpDAT shrink splice protection
15090401-E	OpDAT crimp splice protection (12 pcs)



Illustrations

Dimensional drawing

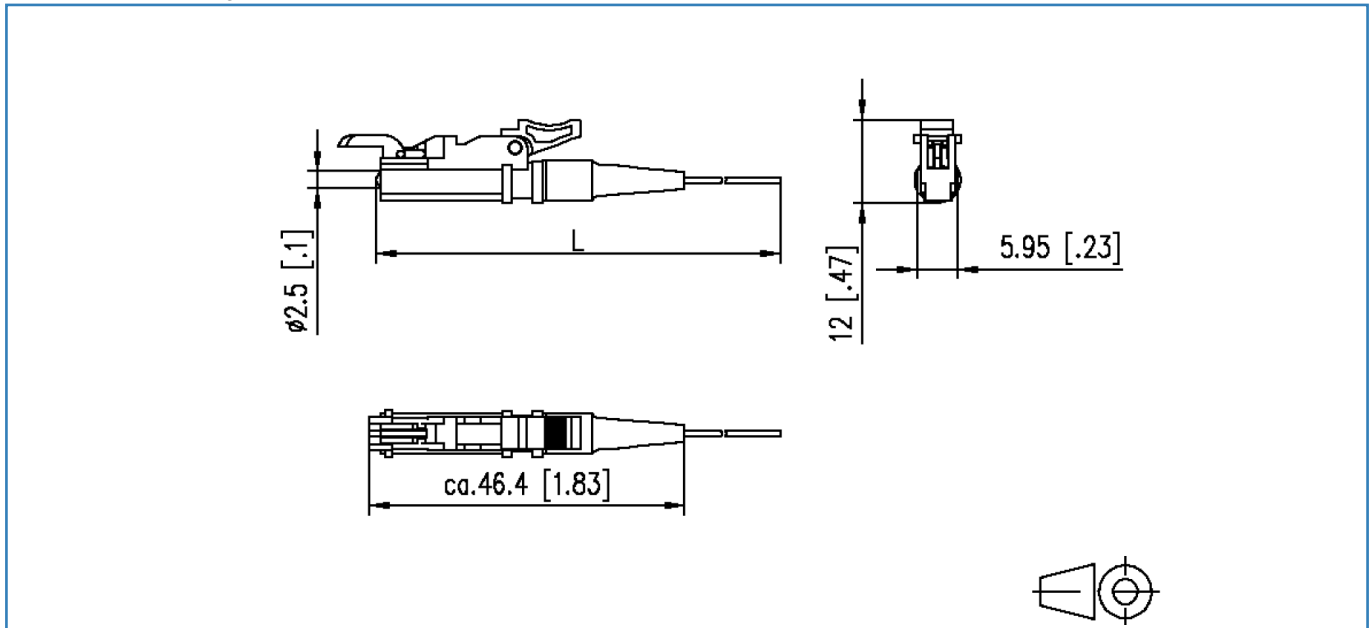

Technical Data

General Data

Transmission technology	Fiber optic
Mode type of the fiber	Single mode
Fiber class	OS2 (IEC 60793-2-50 B.1.3, B6_b & ITU-T G.657.A2, G.657.B2, G.652.D)
Fiber construction	9/125 µm

Transmission characteristics

Chromatic dispersion coefficient	
Chromatic dispersion coefficient - In the interval 1285 nm - 1330 nm (max.)	max. 3.7 ps/km * nm
Chromatic dispersion coefficient - At 1550 nm (max.)	max. 18.5 ps/km * nm
Chromatic dispersion coefficient - At 1625 nm (max.)	max. 23.0 ps/km * nm
Dispersionsnulldurchgang, λ_{D0}	1300-1324 nm
Zero dispersion slope (max.)	0.092 ps/(nm ² * km)
Polarisation mode dispersion (PMD) coefficient, cabled (min.)	0.1
PMDQ Link Design Value (min.)	0.06 ps/vkm
Threshold wavelength (max.)	1260

Connections/interfaces

Connector technology interface 1	Free line end
Connector technology interface 2	Free line end
Core-/ Fiber cladding diameter	125.0 ± 0.7 µm
Primary coating diameter - colored	242 ± 7 µm

Optical characteristics

Attenuation of the fiber	
Attenuation of the fiber in the cable at 1310 nm	max. 0.38 dB/km
Attenuation of the fiber in the cable at 1383 nm	max. 0.38 dB/km
Attenuation of the fiber in the cable at 1550 nm	max. 0.23 dB/km
Attenuation of the fiber in the cable at 1625 nm	max. 0.25 dB/km

Mechanical characteristics

Proof stress level	min. 0.7 (~ 1 %) GPa
Strip force (peak)	1.2 ≤ F _{peak.strip} ≤ 8.9 N
10 turns on a mandrel R= 15 mm, @ 1550 nm	0.03 dB



Technical Data

Mechanical characteristics

10 turns on a mandrel R= 15 mm, @ 1625 nm	0.1 dB
1 turn on a mandrel R= 10 mm, @ 1550 nm	0.1 dB
1 turn on a mandrel R= 10 mm, @ 1625 nm	0.2 dB
1 turn on a mandrel R= 7.5 mm, @ 1550 nm	0.5 dB
1 turn on a mandrel R= 7.5 mm, @ 1625 nm	1.0 dB
Fiber cladding non-circularity	max. 0.7 %
Core (MDF)-cladding concentricity error	max. 0.5 µm
Primary coating concentricity error	max. 5 %
Primary coating-cladding concentricity error	max. 12
Inhomogeneity of OTDR measurement report at 1310 nm und 1550 nm	max. 0.1 dB/km
Group refractive index	
Group refractive index at 1310 nm	1.467
Group refractive index at 1550 nm and 1625 nm	1.468

The product meets the following standards

Generic cabling systems	
General requirements	ISO/IEC 11801 DIN EN 50173-1 : 2007 cat. OS2
Optical fibers: Measuring methods and test procedures	
Fibre geometry	ISO/IEC 60793-1-20
Coating geometry	ISO/IEC 60793-1-21
Length measurement	ISO/IEC 60793-1-22
Fibre proof test	ISO/IEC 60793-1-30
Coating strippability	ISO/IEC 60793-1-32
Attenuation	ISO/IEC 60793-1-40
Chromatic dispersion	ISO/IEC 60793-1-42
Threshold wavelength	ISO/IEC 60793-1-44
Mode field diameter	ISO/IEC 60793-1-45
Macrobending loss	ISO/IEC 60793-1-47
Polarization mode dispersion	ISO/IEC 60793-1-48
Optical fibers: Indoor optical cables	
Sectional specification for class B single-mode fibres	ISO/IEC 60793-2-50 type B6_a/B6_b



Data sheet OpDAT fiber OS2 BR

Page 8/8

P/N
150XXX9

2018-09-01

Technical Data

The product meets the following standards

Optical fibers: Outdoor optical fibre cables

Outdoor cables ISO/IEC 60794-3

ITU-T standard G.657.A2, G.652.B2, G.652.A, B, C, D

Packing details

Type of packaging 0

Packaging dimension (W x H x D) 0.00 x 0.00 x 0.00 mm

